

PT4C35A HYDROGEN THYRATRON



The Penta Laboratories PT-4C35A is a three element, hydrogen filled thyratron incorporating a unipotential cathode and designed for network discharge service. The PT-4C35A is specially designed for low jitter and exceptionally high power output of up to 350 kilowatts. In addition, the PT-4C35A is equipped with a hydrogen reserve reservoir to ensure maximum shelf life and a long stable operating life.

GENERAL CHARACTERISTICS

	MIN.	MAX.	NOM.	
Heater Voltage	5.75	6.60	6.30	AC Volts
Heater Current (@6.3 volts)	5.50	6.70		Amperes
Minimum Preheating Period	3.00			Minutes

MECHANICAL CHARACTERISTICS

Base	A4-18, 4 Pin Bayonet with Ceramic Insert			
Maximum Overall Dimensions:				
Height	6.875	Inches		
Diameter	2.562	Inches		
Approximate Net Weight	8.0	Ounces		
Mounting Position	Any			
Cooling	Convection or Forced Air			

MAXIMUM RATINGS

Maximum Peak Forward Anode Voltage	8.0	Kilovolts
Maximum Peak Inverse Anode Voltage ¹	8.0	Kilovolts
Minimum Anode Supply Voltage	2.5	DC Kilovolts
Maximum Peak Anode Current	90	Amperes
Maximum Average Anode Current	100	Milliamperes
Maximum RMS Anode Current ²	3.0	AC Amperes
Maximum $e_{py} * i_b * p_{rr}$	2.0×10^9	
Maximum Anode Current Rate of Rise	1000	Amperes/ μ s
Maximum Peak Inverse Trigger Voltage	200	Volts
Maximum Initial Anode Delay Time ³	0.6	Microseconds
Maximum End of Life Anode Delay Time ³	0.7	Microseconds
Maximum Anode Delay Time Drift	0.1	Microseconds
Maximum Initial Time Jitter ⁴	0.01	Microseconds
Maximum End of Life Time Jitter ⁴	0.01	Microseconds
Permissible Ambient Temperature	-50 to 90	$^{\circ}$ C

Revised 05/17/00



P E N T A L A B O R A T O R I E S , I N C .

9740 COZYCROFT AVENUE * CHATSWORTH * CALIFORNIA 91311
(800) 421-4219 * (818) 882-3872 * FAX (818) 882-3968



PT4C35A Hydrogen Thyatron

With regard to Peak Trigger Voltage, the voltage between the cathode and grid terminals (with the tube removed) should be maintained between 175 and 250 volts with a duration of 2 microseconds at 70% points, an impedance source not exceeding 1500 X, and a rate of rise of 200 volts per microsecond. The limits of anode time jitter and time delay are for minimum trigger; these values can usually be significantly reduced by using the highest possible trigger voltage and the lowest possible trigger source impedance (within specified limits).

NOTES:

- 1- In pulsed operation the peak inverse voltage exclusive of spike of 0.05 microseconds maximum duration, shall not exceed 2.5 Kilovolts during the first 25 Microseconds after the pulse.
- 2- Root mean square anode current is defined as the square root of the product of the peak anode current and the average (mean) anode current.
- 3- Anode delay time is measured between the 26% point on the rising portion of the unloaded grid voltage pulse and the point at which evidence of anode conduction first appears on the loaded grid pulse.
- 4- Time jitter is measured at the 50% point on the anode current pulse.

TYPICAL OPERATION

Pulse Modulator, DC Resonant Charging

Peak Network Voltage	8.0	Kilovolts
Pulse Repetition Rate	2800	Pulses per Second
Pulse Length	0.40	Microseconds
Pulse Forming Network Impedance	46.9	X
Trigger Voltage	200	Volts
Peak Power Output (resistive load of 92% <i>zn</i>)	330	Kilowatts
Peak Anode Current	89	Amperes
Average Anode Current	0.10	DC Amperes



PT4C35A Hydrogen Thyatron

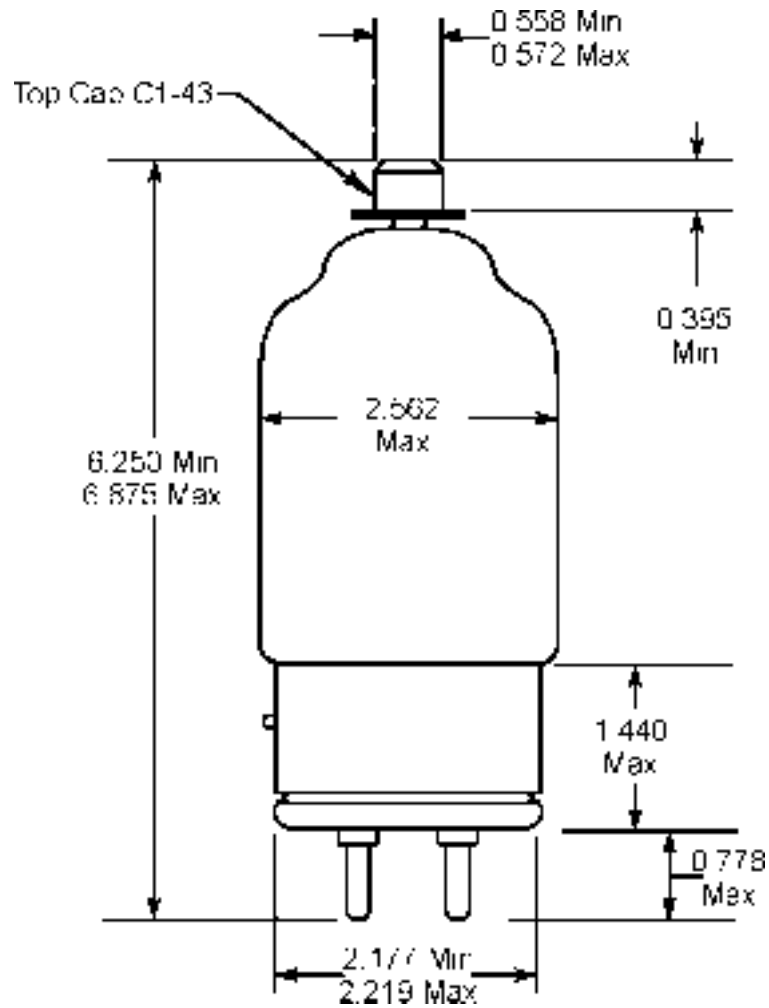

- 1. GRID
- 2. CATHODE AND HEATER
- 3. HEATER
- 4. CATHODE

